

# FILTER OVERVIEW WITH SERVICE INTERVALS AND CAPACITIES

## 9650 STS, 9750 STS Series Combines

### ENGINE AIR FILTER

SECONDARY AIR FILTER (9650) – [RE63932](#)

SECONDARY AIR FILTER, HIGH CAPACITY (9650-9750) – [AH164063](#)

Change secondary filter only with primary filter.

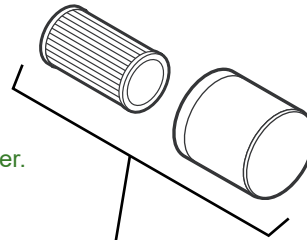

### ENGINE AIR FILTER

PRIMARY AIR FILTER (9650) – [AH148880](#)

PRIMARY AIR FILTER, HIGH CAPACITY (9650-9750) – [AH164062](#)

Replace every 400 hours or service filters only when engine air filter light stays ON or change as required.

Note: Replace Secondary Filter with Primary Filter.

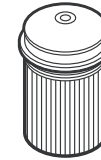

### ENGINE OIL FILTER

OIL FILTER (9650-9750) – [RE57394](#)

For Engine 6081HH005, 6081HH006 Up To Engine Serial Number ( -199999).

OIL FILTER (9650-9750) – [RE509672](#)

For Engine 6081HH012, 6081HH013 From Engine Serial Number (200000 - ).

Replace every 200 hours

Note: Change oil every 100 hours if fuel contain more than 0.5% sulfur.

Change oil every 250 hours when using TORQ-GARD SUPREME® PLUS-5W™

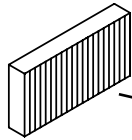

### CAB AIR FILTER

RECIRCULATION AIR FILTER – [AH115836](#)

Clean or replace every 200 hours and as required.

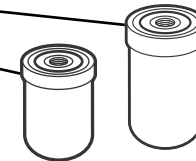

### ENGINE FUEL FILTER

FUEL FILTER – [AR86745](#)

For Engine 6081HH005, 6081HH006 Up To Engine Serial Number ( -199999).

FUEL FILTER – [RE522372](#)

For Engine 6081HH012, 6081HH013 From Engine Serial Number (200000 - ).

PRIMARY FUEL FILTER – [RE531703](#)

For Engine 6081HH012 From Engine Serial Number (232463- ).

PRIMARY FUEL FILTER – [R502778](#)

For Engine 6081HH012 Up To Engine Serial Number ( -232462).

For Engine 6081HH013 From Engine Serial Number (200000 - ).

SECONDARY FUEL FILTER – [RE522688](#)

For Engine 6081HH012 From Engine Serial Number (232463- ).

For Engine 6081HH013 From Engine Serial Number (200000 - ).

SECONDARY FUEL FILTER – [RE522372](#)

For Engine 6081HH012 Up To Engine Serial Number ( -232462).

For Engine 6081HH013 From Engine Serial Number (200000 - ).

SECONDARY FUEL FILTER – [RE522687](#)

For Engine 6081HH013 From Engine Serial Number (200000 - ).

FUEL WATER SEPARATOR FILTER – [RE500186](#)

For 9650 ( -695500) and For 9750 ( -695600).

Replace every 500 hours.

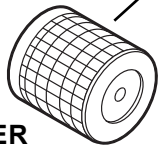
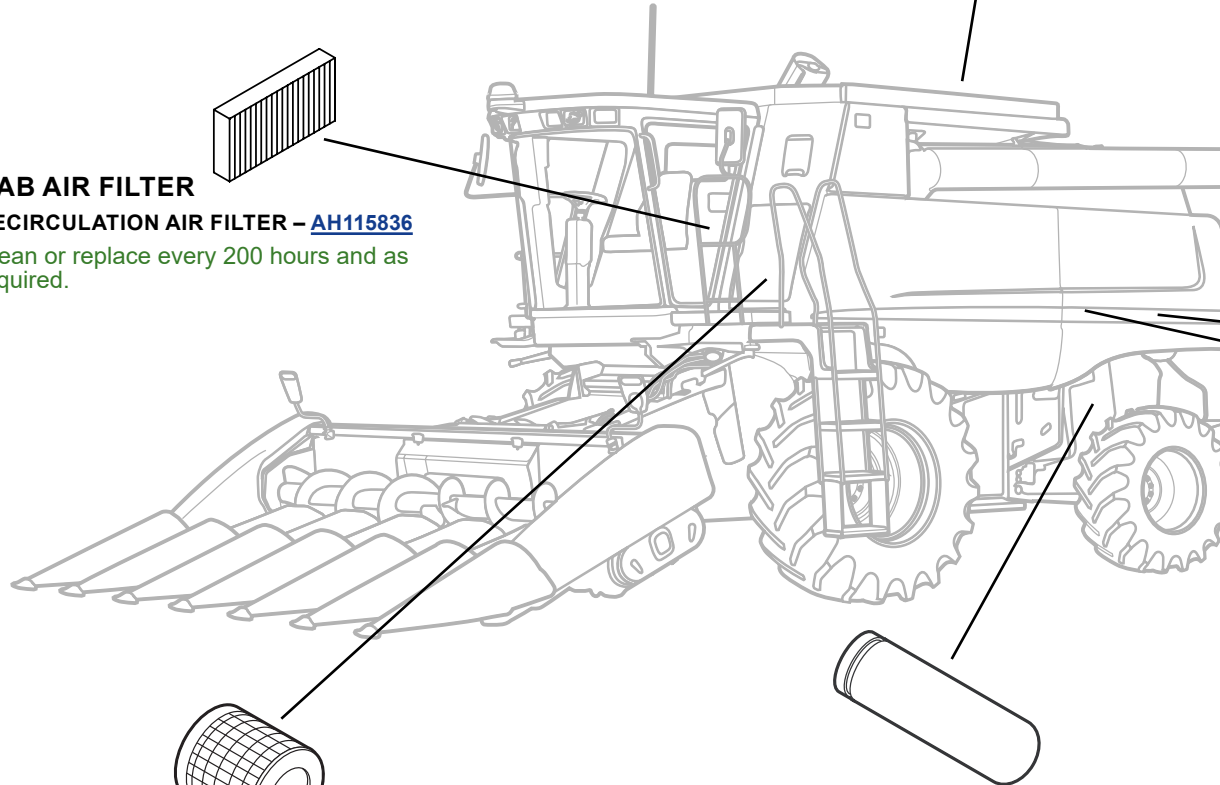

### CAB AIR FILTER

AIR FILTER, HEAVY DUTY – [AH168783](#)

AIR FILTER, STANDARD – [AH115833](#)

Clean or replace after 50 hours and as required.

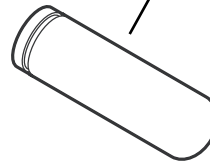

### HYDROSTATIC PUMP / ENGINE GEARCASE / HYDRAULIC FILTER

OIL FILTER – [AH128449](#)

Replace every 400 hours.

Note: Replace all three filters at a time.

(Click here for [capacity](#))



**JOHN DEERE**

Genuine Parts and Service

# CAPACITIES

## 9650 STS, 9750 STS Series Combines

### **CAPACITIES (Approximate):**

#### **Fuel Tank:**

For 9650 ( -695500), 9750 ( -695600)..... 757 L (199.97 gal)

For 9650 (695501- ), 9750 (695601- )..... 945 L (249.64 gal)

#### **Cooling System With Heater:**

For 9650 ( -695500), 9750 ( -695600)..... 38 L (10.03 gal)

#### **Cooling System Without Heater:**

For 9650 ( -695500), 9750 ( -695600)..... 45 L (11.88 gal)

#### **Hydraulic / Hydrostatic Reservoir:**

..... 34 L (8.98 gal)

#### **Feeder House Reverser Gearcase:**

Standard..... 0.9 L (0.23 gal)

High Capacity Without Cooler ..... 1.8 L (0.47 gal)

High Capacity With Cooler ..... 3.5 L (0.92 gal)

#### **Final Drives (Each):**

Single Reduction ..... 8.5 L (2.24 gal)

#### **Countershaft Drive Gearcase:**

..... 1.2 L (0.31 gal)

#### **Loading Auger Gearcase:**

..... 3.8 L (1 gal)

#### **Engine Gearcase With Transfer:**

..... 21.3 L (5.62 gal)

#### **Engine Crankcase With Filter:**

..... 28.5 L (7.52 gal)

#### **Transmission:**

..... 9.6 L (2.53 gal)

#### **Two Speed Seperartor Drive Gearcase:**

..... 4.7 L (1.24 gal)

[Return to Filter Overview](#)

